

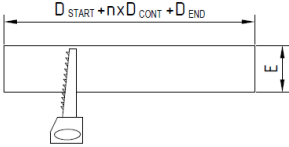

HVL /R

1390001111

• Directions for use • Návod k použití • Návod k použitiu • Bedienungsanleitung • Instrukcija montažu oprawy • Használati utasítás • Lietošanas pamācība • Naudojimosi instrukcija • Kasutamisi juhend • Instructiuni de folosire • Uputstvo za upotrebu • Navodilo za uporabo • Monteringsanvisning • Угъгване • Manual de instrucciones • Gebruiksaanwijzing • Mode d'emploi • Istruzioni per l'uso • Monteringsveledning • Modo de emprego • ΝΕΑΚΑΤΕΥΘΥΝΣΗΙΑΧΡΗΣΗ



HVL /R (mm)	A _{START}	A _{CONT,END}	B	C	D		
					D _{START, END}	D _{CONT}	E
HVL M/R	1207	1197	90	100	1190	1185	75

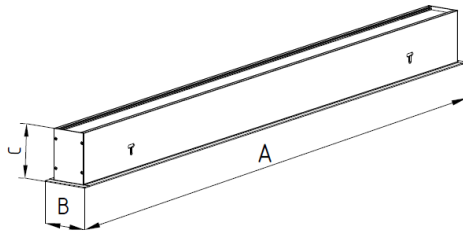
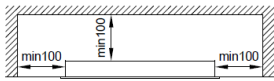

≈ 230-240V / 50Hz / max 16 A

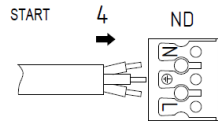
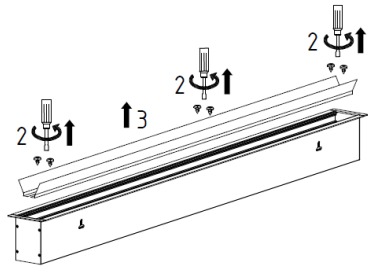
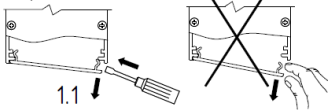
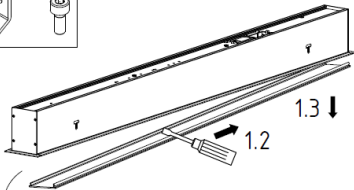
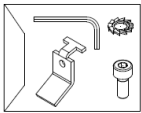
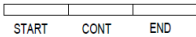

ND

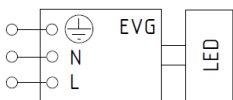

DIM, DALI

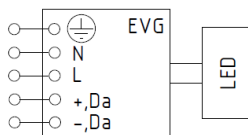

DIM, DALI



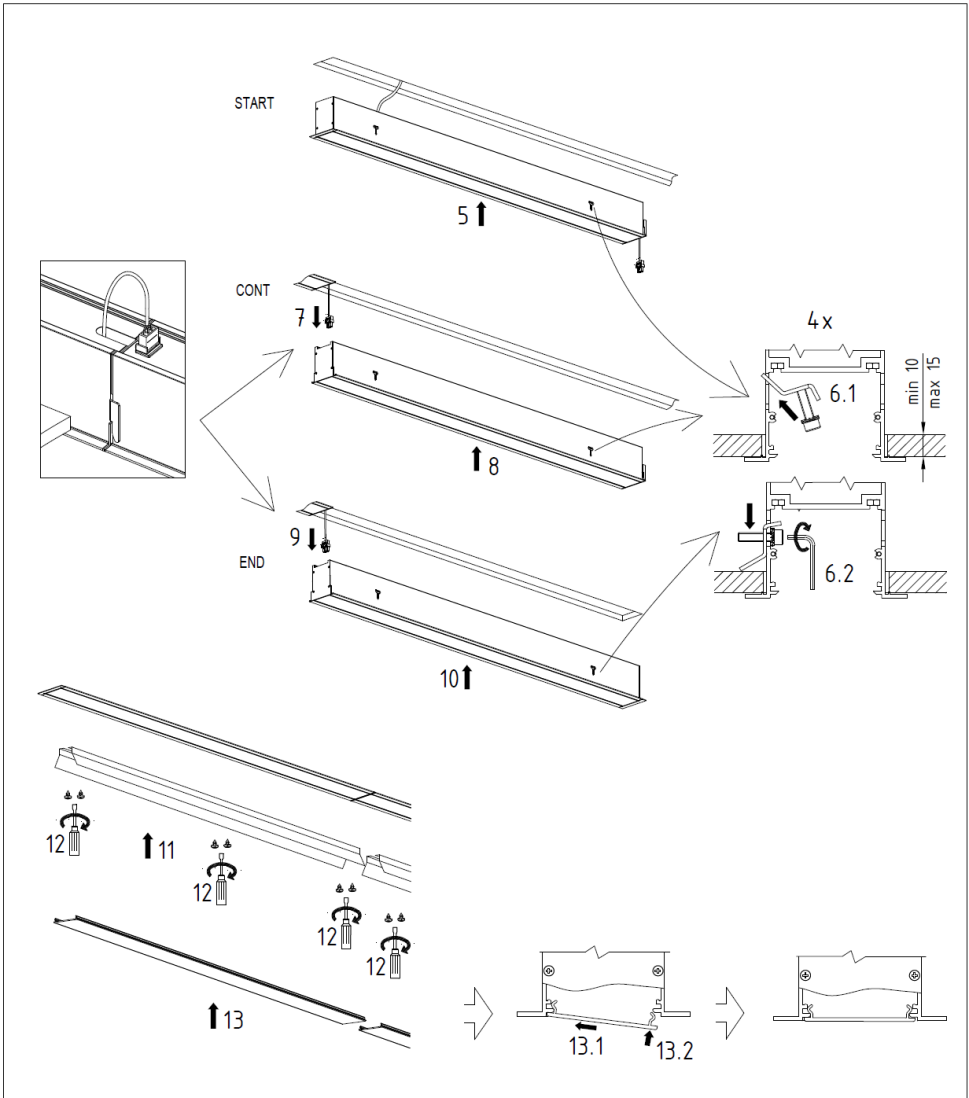

Upozornění! Montáž svítidla smí provádět pouze odborná elektromontážní firma nebo osoba s elektrotechnickou kvalifikací.
 Attention! The lighting unit may only be assembled by a skilled firm or by person with electrotechnical qualification.
 Sicherheitshinweis! Die Montage und die elektrische Installation der Leuchte muss von einer Elektrofachkraft durchgeführt werden.

Na tento výrobek se poskytuje záruka 60 měsíců od data prodeje. Záruka se nevztahuje na závady způsobené nevhodným zacházením. The warranty period of this product is 60 months from the purchase date. The warranty doesn't cover damage caused by improper handling.

SWE

Varning! Belysningsarmaturen bör endast monteras av behörig elektriker.

EST

Ettevaatust! Valgustit võib paigaldada ainult autoriseeritud elektrik!

NOR

Viktig: Armaturen må kun tilkobles av autorisert elektroinstallatør

FIN

Huomio: Valaisimen saa asentaa vain sähköalan ammattilainen

ROM

Atentie! Montarea corpurilor de iluminat se va face de catre firme specializate sau persoane calificate in domeniul electrotehnic.

DEN

VIGTIGT! PRODUKTET MÅ KUN INSTALLERES AF AUT. EL-INSTALLATØR

LIE

Dėmesio! Šviestuvus turi būti surinktas ir sumontuotas tik specialios įmonės arba kvalifikuoto elektriko.

RUS

Внимание! Светильник должен устанавливаться специализированной фирмой или лицом обладающим электротехнической квалификацией.

ITA

ATTENZIONE! GLI APPARECCHI DEVONO ESSERE INSTALLATI DA DITTE SPECIALIZZATE O DA INSTALLATORI QUALIFICATI.

ISL

Athugið: Eingöngu löggiltir rafverktakar meiga setja upp lampann

POR

A armadura de imluninação só deve ser ligada por uma firma especializada ou por um técnico qualificado.

LAT

Uzmanību! Apgaismes ierīces uzstādīšanu drīkst veikt tikai sertificēts elektriķis vai sertificēts elektromontāžas uzņēmums.

FRA

Attention! les luminaires doivent être poses par des sociétés spécialisees ou par des personnes compétentes ayant le diplôme d'electrotechnicien.

SLK

Montáž svetidla môže vykonať iba osoba s elektrotechnickou kvalifikáciou

POL

Montaż oprawy może wykonać tylko osoba posiadająca odpowiednie elektrotechniczne uprawnienia.

NED BEL

Let op ! Deze verlichtings unit mag alleen worden gemonteerd door een daartoe bekwaamde firma of door een persoon die elektrotechnisch is gekwalificeerd.

HUN

A lampatestek beszerelését csakis elektrotechnikai vegzettseggel rendelkezo szemely veggezheti el.

HR BiH

Montažu svjetiljke može izvršiti samo stručno kvalificirana osoba.

SLO

Montažo svetilke lahko izvede samo strokovno kvalificirana oseba.