

ALDER 400-800-1000

-COD. 602201

-COD. 602202

-COD. 602203

ASSEMBLY AND OPERATING INSTRUCTIONS:



-Class II double insulated luminaire (not earthed)

CE Made in Italy **IP66**



Directive 2002/96/CE (Waste Electrical and Electronic Equipment– WEEE)

Information for users:

The crossed out wheeled bin label that can be found on your product indicates that this product should not be disposed of via the normal household waste stream. To prevent possible harm to the environment or human health please separate this product from other waste streams to ensure that it can be recycled in an environmentally sound manner. For more details on available collection facilities please contact your local government office or the retailer where you purchased this product.



Retain the instructions

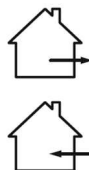

The article is suitable for indoor and outdoor use

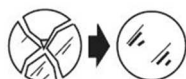

Replace the damaged protective glass



Do not use high pressure cleaners

COD. 602201

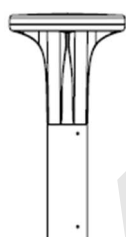

400mm

DIAM 70mm

ALDER 400

- Power consumption : 20W
- Voltage : 220-240V 50/60Hz
- Color Temperature : 3000K - 4000K
- Beam angle : 360° radial
- Insulation class: II
- IK rating : IK09
- IP protection: IP66
- Gross weight: 3kg

COD. 602202

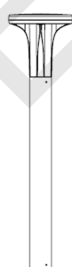

800mm

DIAM 70mm

ALDER 800

- Power consumption : 20W
- Voltage : 220-240V 50/60Hz
- Color Temperature : 3000K - 4000K
- Beam angle : 360° radial
- Insulation class: II
- IK rating : IK09
- IP protection: IP66
- Gross weight: 4.3kg

COD. 602203



1000mm

DIAM 70mm

ALDER 1000

- Power consumption : 20W
- Voltage : 220-240V 50/60Hz
- Color Temperature : 3000K - 4000K
- Beam angle : 360° radial
- Insulation class: II
- IK rating : IK09
- IP protection: IP66
- Gross weight: 4.8kg

Recommendations

- Verify that the equipment used to connect our devices to enjoy all the guarantees required under European law;
- Use the cables, connectors and quality materials for electrical wiring;
- Products with IP66 degree make the wiring / connections with accessories provide the same degree IP of the selected product (available in the catalog);
- In the case of installations outside is not recommended to install the power supplies in the formwork and / or in the junction box without adequate protection

A scheduled maintenance programme must be carried out on the installation and the fittings regardless of their IP rating or application – these must include the following operations:

- Clean the fittings from dirt that may be deposited on the protection grills and in the heads of the screws by following the installation instructions attached to each fitting.

-Check that the screws are not loose on the various components of the luminaire (glass frame, cable entry ,).

-Check each cable gland, and cable for damage and that the cable gland has not come loose.

-For each Isolation Class 1 fitting check that the earth cable has not come loose. The clip must not show signs of oxidation, damage or become loose.

-Check that all the seals are in good condition and that they are not dry, damaged or split.

-Check the glass or plastic screen for damage and replace if required.

-Check for water inside the luminaire's housing and its recessing box.

-The internal components such as the ballasts, transformers, washers and screws must not show clear signs of oxidation or rust. Clear traces of rust and oxidation will indicate the presence of water inside the luminaire.

-In case of damage the components must be replaced by original components and spare parts before using the fitting.

We also recommend to check the fitting each time the lamp is replaced or at least once a year or within the prescribed maintenance schedule period depending on the type of installation.

-Terminal block not included. Installation may require advice from a qualified person. For wiring use a terminal complies with EN60998-2-1, EN 60998-2-2. The IP rating of the electrical connection must be equal to or greater than the IP rating of the luminaire.

Note on corrosion protection

For installation and maintenance be especially careful not to damage the coating powder . Damage combined action of water could cause corrosion.

-In the case of damage to the external flexible cable, it must be replaced by the manufacturer, or its assistance service, or equivalent qualified personnel in order to avoid dangers

-In the case of glass breakage, contact the device manufacturer to replace it. Replace the screen with an original replacement

Installation:

1. Loose the grub-screws in the base of the luminaire using the tool included in the package and remove the fixing plate pic.1
2. Prepare holes in corrispondance of the feeding point using fischer plugs pic. 2-3
3. Fix the base to the floor by tighten the screws of the fischer plugs pic.4
4. Make the adequate electrical connection pic. 5
5. Place the luminaire by tighten the grub-screws of the base using the tool included in the package pic. 6

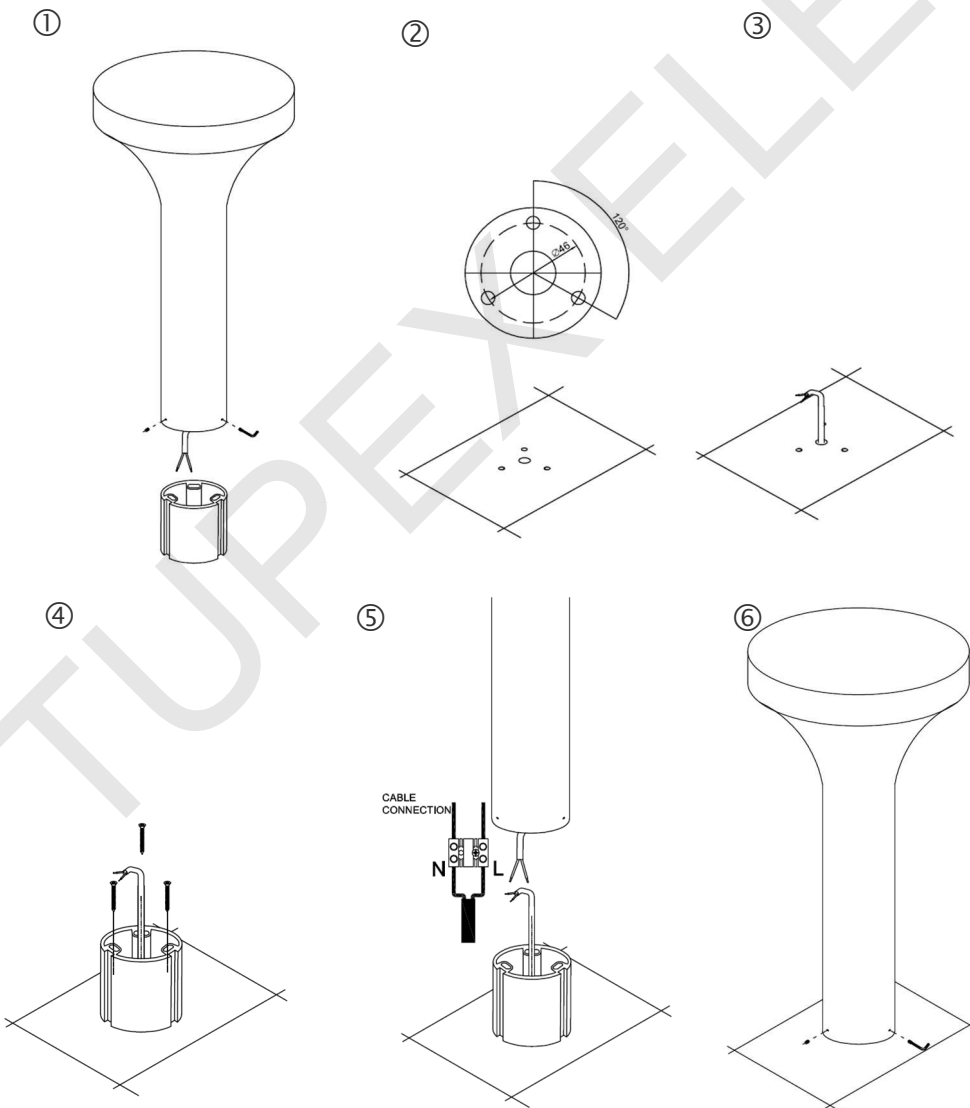

Use only supply cables with double case



CABLE CONNECTION

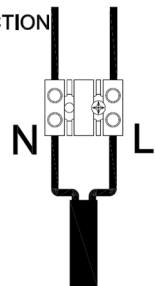

CLASS II

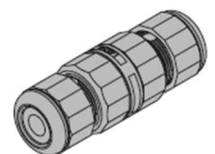

See the connector accessory instruction

COD. AC065 HANCORAGE UNIT FOR ALDER SERIES

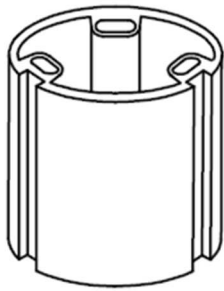

PLASTIC BASE

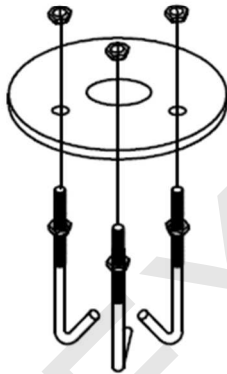

STEEL BASE

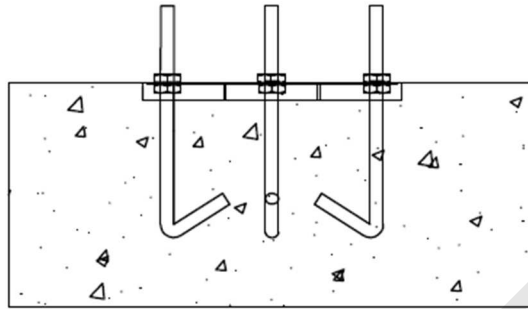

1 PLACE THE BASE INTO CONCRETE BED

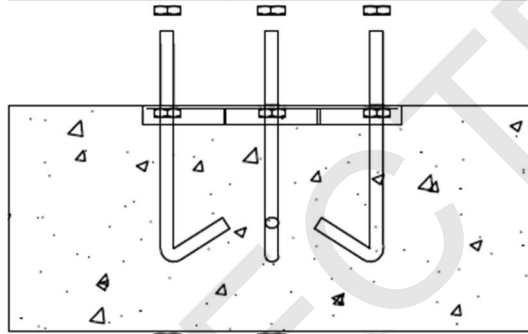

2 UNSCREW AND REMOVE 3 NUTS

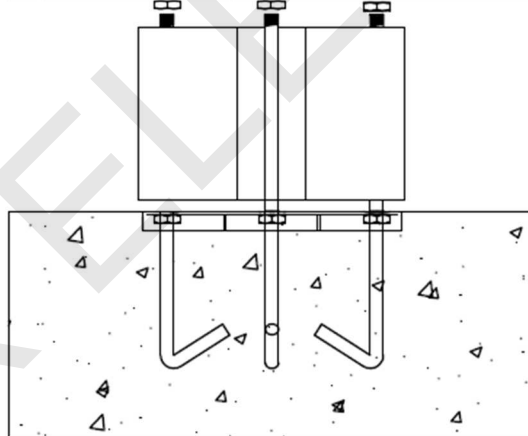

3 INSERT THE PLASTIC BASE AND FIX IT USING 3 NUTS

TUPLEX