

# HYDROFLOOR MAXI COB + COB ASYMMETRIC

COD 201069

COD 201071

## ASSEMBLY AND OPERATING INSTRUCTIONS:



-Class I fitting electric grounding is needed

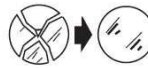

- replace the damaged protective glass
- sostituire i vetri di protezione se danneggiati
- die Beschädigten Schutzgläser ersetzen
- remplacer les verres de protection abimés
- glass features: plane float glass - safety tempered
- caratteristiche vetro: vetro piano float di sicurezza temperato
- Glaseigenschaften: Float-Flachglas, gehärtetes Sicherheitsglas
- caractéristiques du verre: type de verre: plan "float" de sûreté trempé



-getting rid of as urban waste forbidden  
-separate collection is mandatory when the product is at the end of its life



Made in Italy IP67

	GB Retain the instructions.
	I Conservare le istruzioni.
	D Retain the instructions.
	F Bewahren Sie die Anleitung.
	E Conservez ces instructions.

NB: These assembly instructions must be given to end users for correct maintenance and so that they know how to change the bulb. The appliance must not be tampered with or transformed and it must be installed and used as supplied and in compliance with the National Rules on Installations. Any non-compliant installations will invalidate all forms of guarantee. The company cannot be held

**COD. 201069**



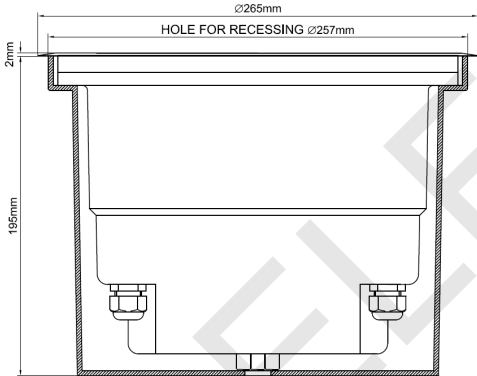

**HYDROFLOOR MAXI COB**

- Power consumption : 32W
- Voltage : 220-240V 50-60Hz
- Color Temperature : 3000K - 4000K
- Beam angle : 20° 40°
- Insulation class: I
- IP protection: IP67
- IK rating IK10
- Adjustable: +15°-15°
- Gross weight: 5,5kg

**COD. 201071**

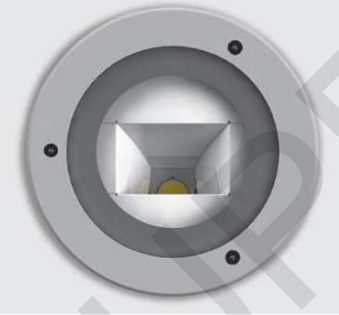

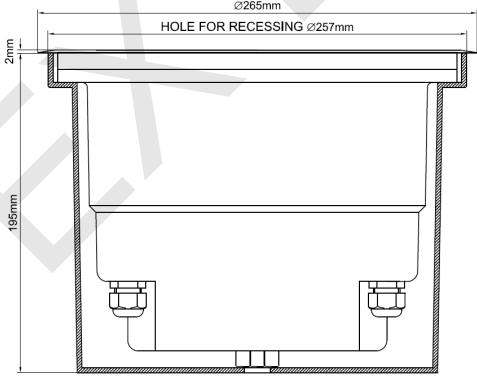

**HYDROFLOOR MAXI COB ASYMMETRIC**

- Power consumption : 32W
- Voltage : 220-240V 50-60Hz
- Color Temperature : 3000K - 4000K
- Beam angle : asymmetric
- Insulation class: I
- IP protection: IP67
- IK rating IK10
- Adjustable: +15°-15°
- Gross weight: 5,5kg



Walk over fittings max static weight 5000kg

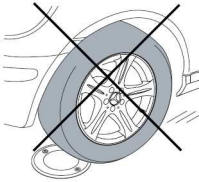

### HYDROFLOOR MAXI COB + COB ASYMMETRIC

The luminaire is supplied by us with LED illuminator already installed with built in SELV power supply.

The cable and the fixture must not be tampered with for any reason.

It is essential to do a frequent cleaning of the glass and of the outer surface of the fixture to avoid build up of mud and dirtiness resulting in dangerous

overheating due to uncorrect light and heat dissipation. Clean carefully the glass screen removing limestone deposits by means of a scraper.

**The replacement must be done by a qualified electrician.**

### Recommendations

- 1) verify that the equipment used to connect our devices to enjoy all the guarantees required under European law;
- 2) use the cables, connectors and quality materials for electrical wiring;
- 3) Products with IP65/68 degree make the wiring / connections with accessories provide the same degree IP of the selected product (available in the catalog);
- 4) In the case of installations outside is not recommended to install the power supplies in the formwork and / or in the junction box without adequate protection
- 5) Terminal block not included. Installation may require advice from a qualified person. For wiring use a terminal complies with EN60998-2-1, EN 60998-2-2

### Choice of installation location

The unit should be positioned so that when in use is not subject to direct radiation from the sun or other heat sources . High temperatures reduce the life and efficiency of the components or the LED module .

### Note on corrosion protection

- Install recessed in the ground so that water can flow away from the surface of the device. Both for the recessed directly in the ground , both for the use of a recessed housing , it is necessary to perform a further drainage , for example , using a bed of gravel.- For installation and maintenance must be especially careful not to damage the coating powder . Damage combined action of water could cause corrosion.

Recommend mounting the device to the floor with a pH value between 5 and 8. In ambient environment the assembly and maintenance of all components require the appropriate security measures . The chemicals damage the corrosion protection

### INSTALLATION:

#### -SWITCH-OFF THE POWER SUPPLY BEFORE CARRYING OUT ANY MAINTENANCE OPERATIONS

1. place the formwork 115mm from floor level
2. loose the screws placed on the stainless steel disk. (with appropriate key included in the package)
3. Open the luminaire by ancrewing the screws placed on the aluminium ring
4. Connect the power cable to the initial power supply line using the appropriate connector
5. Insert the device in the formwork and fix it by using the self threading screws. (included in the package)
6. Close the luminaire putting the glass the aluminium ring and the steeldisk tightening the screws

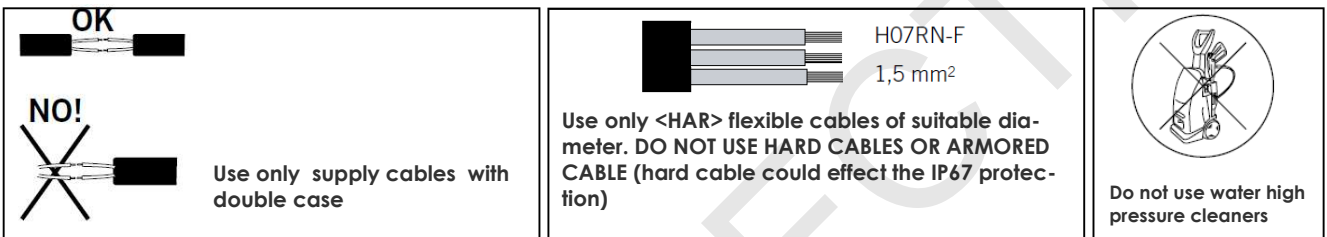

STEEL FRAME

ALLUMINIUM  
FRAME

GLASS+GASKET

ALUMINIUM  
CASE

RECESSING BOX

CONCRETE

GRAVEL+SAND

